

Steadycam - AJ/2011

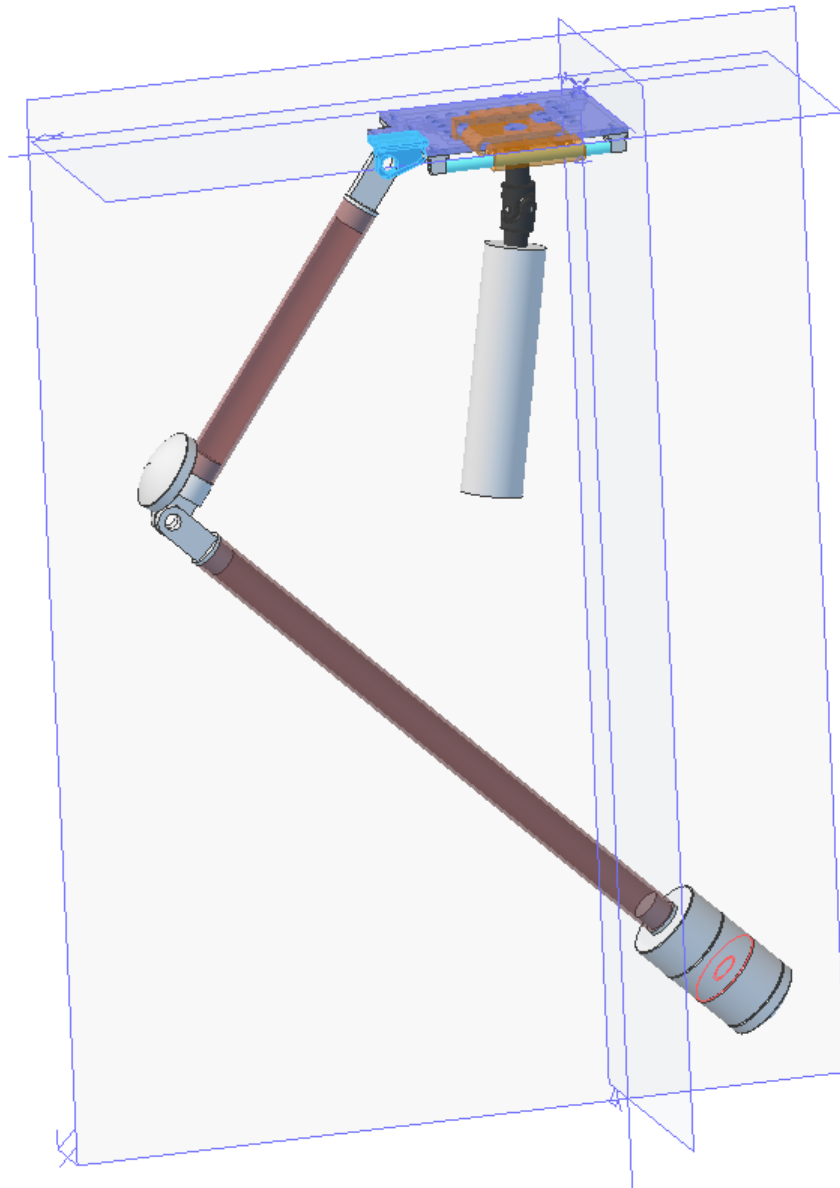

1

2

3

4

5

6

7

8

RevNo	Revision note	Date	Signature	Checked
-------	---------------	------	-----------	---------

A

B

C

D

E

F

A

B

C

D

E

F

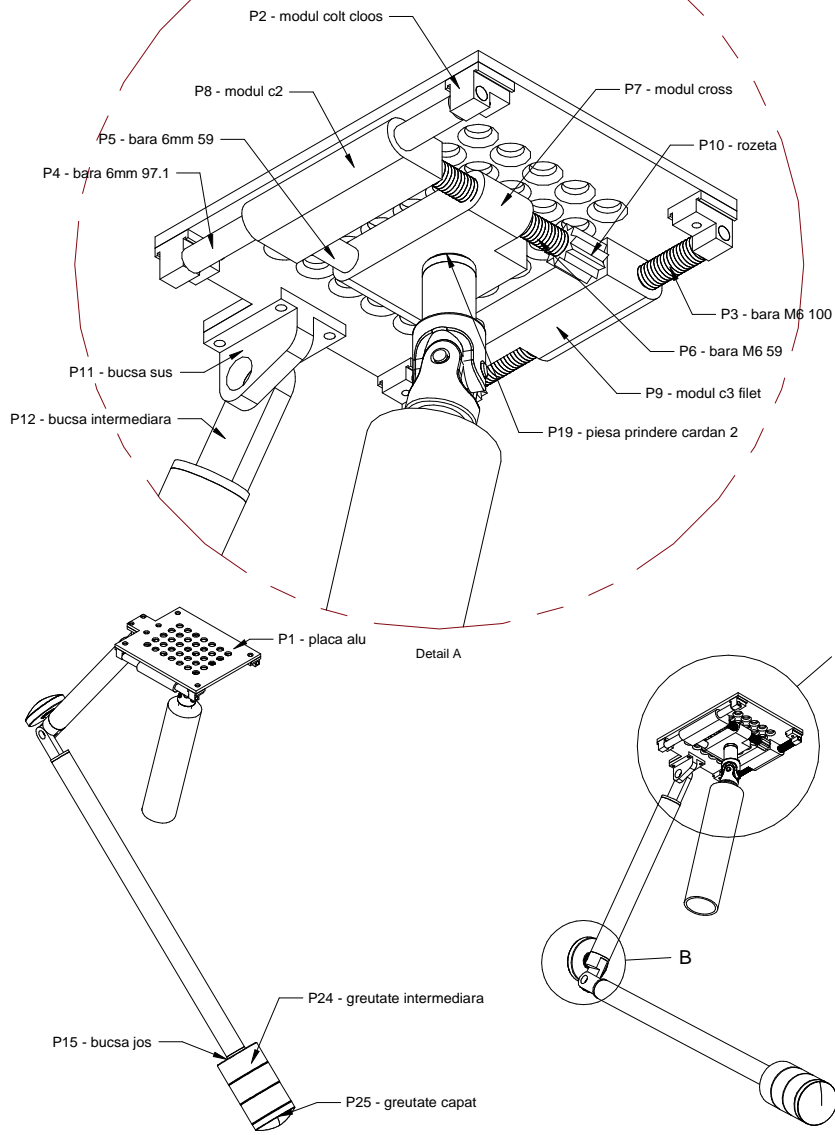

Item Number	Quantity	Part Number	Part Name	Revision	Comment
1	1		01_placa alu	v03	
2	4		02_modul_colt_cloos	v03	exista
3	1		03_bara_6mm_filetata_100	v03	
4	1		03_bara_6mm_97_1	v03	
5	1		03_bara_6mm_59_2_3	v03	
6	1		03_bara_6mm_filetata_59	v03	
7	1		06_modul_cross	v03	
8	1		04_modul_c2	v03	
9	1		04_modul_c3_filet	v03	
10	2		07_rozeta	v03	
11	1		16_bucs_sus	v03	
12	2		15_bucs_intermediara	v03	
13	1		15_bucs_intermediara2	v03	
14	1		17_bucs_cu_filet	v03	
15	1		16_bucs_jos	v03	
16	1		30_teava_fi20_150mm	v03	
17	1		31_teava_fi20_300mm	v03	
18	1		24_piesa_prindere_cardan	v03	surub M5
19	1		25_piesa_prindere_cardan2	v03	
20	2	1	ball_bearing_-_618_5_0_01	v03	exista
21	1		23_bucs_intre_rulmenti	v03	
22	2		20_tija_cardan	v03	exista
23	1		21_bila_cardan	v03	exista
24	2		11_greutate_capat	v03	
25	5		10_greutate_intermediara	v03	
26	1		33_maner	v03	de gasit ulterior

Itemref	Quantity	Title/Name, designation, material, dimension etc			Article No./Reference	
Drawn by AJ	Checked by	Approved by - date	File name	Date 02.2011	Scale	
				Edition	Sheet	

1

2

3

6

7

8

1

2

3

4

5

6

7

8

RevNo	Revision note	Date	Signature	Checked
-------	---------------	------	-----------	---------

A

B

C

D

E

F

A

B

C

D

E

F

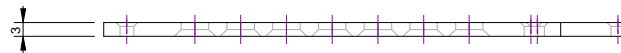
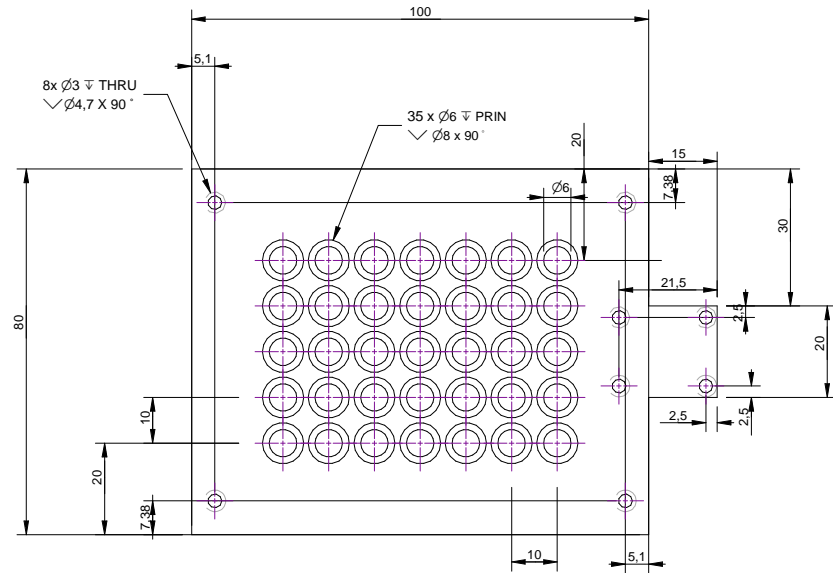
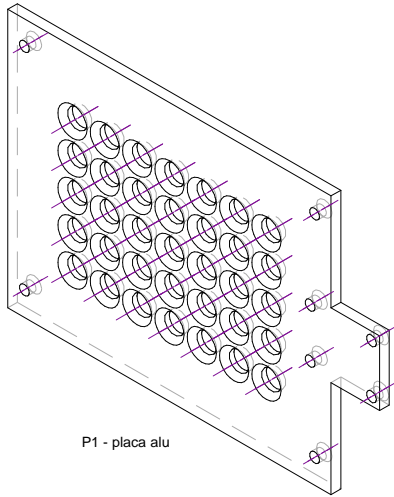

Itemref	Quantity	Title/Name, designation, material, dimension etc			Article No./Reference	
Drawn by		Checked by	Approved by - date	File name	Date	Scale
					Edition	Sheet

1

2

3

6

7

8

1

2

3

4

5

6

7

8

RevNo	Revision note	Date	Signature	Checked
-------	---------------	------	-----------	---------

A

B

C

D

E

F

A

B

C

D

E

F

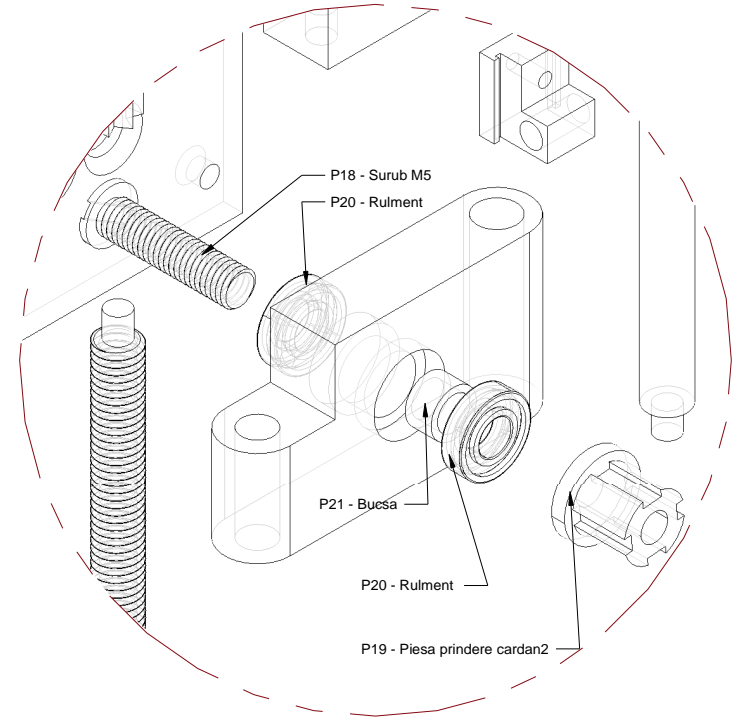
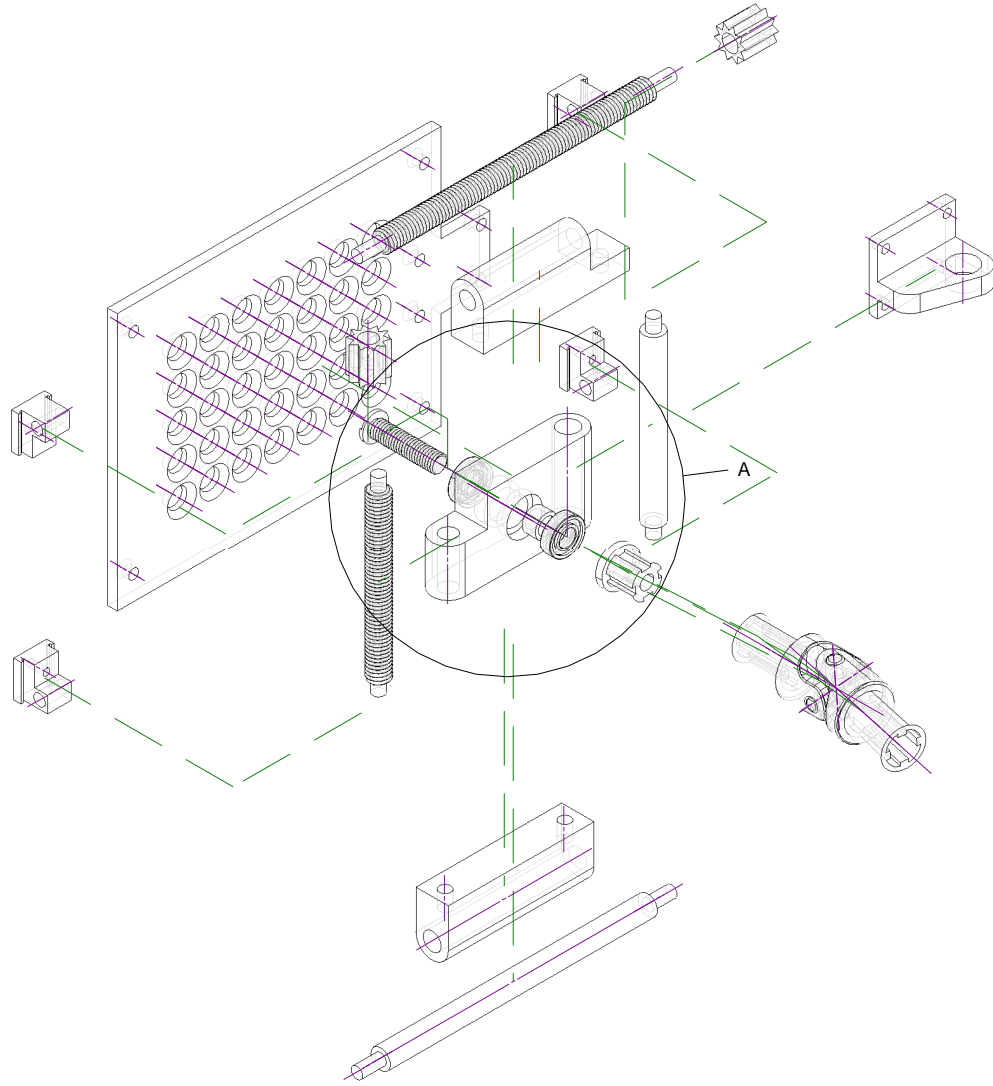

Detail A

Itemref	Quantity	Title/Name, designation, material, dimension etc			Article No./Reference	
Drawn by	Checked by	Approved by - date		File name	Date	Scale
				Vedere explodata placa reglare		
						Edition
						Sheet

1

2

3

6

7

8

1

2

3

4

5

6

7

8

RevNo	Revision note	Date	Signature	Checked
-------	---------------	------	-----------	---------

A

B

C

D

E

F

A

B

C

D

E

F

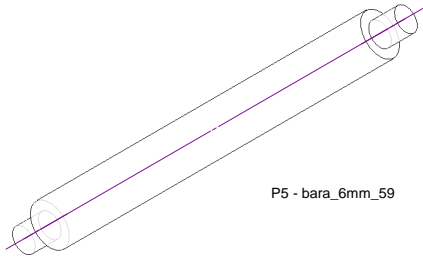

P5 - bara\_6mm\_59

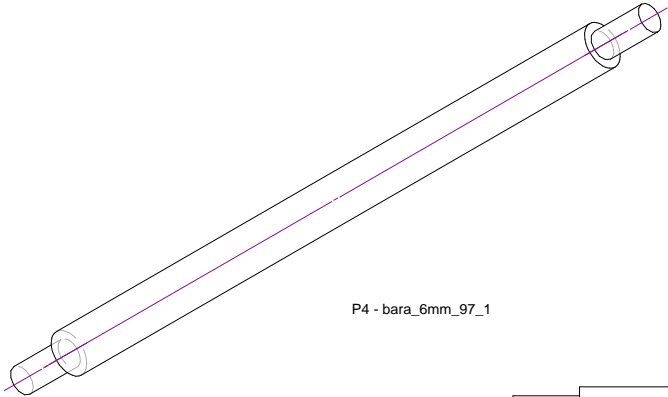
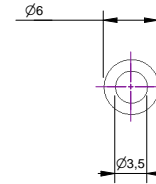
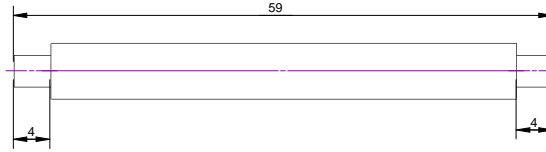

P4 - bara\_6mm\_97\_1

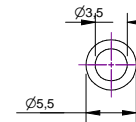
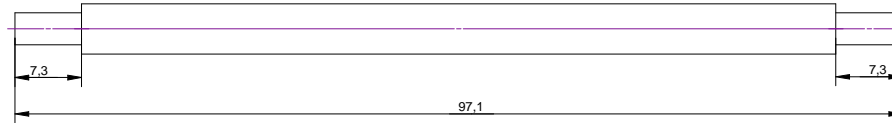

Itemref	Quantity	Title/Name, designation, material, dimension etc			Article No./Reference	
Drawn by		Checked by	Approved by - date	File name	Date	Scale
					Edition	Sheet

1

2

3

6

7

8

1

2

3

4

5

6

7

8

RevNo	Revision note	Date	Signature	Checked
-------	---------------	------	-----------	---------

A

B

C

D

E

F

A

B

C

D

E

F

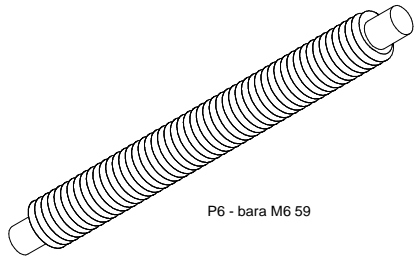

P6 - bara M6 59

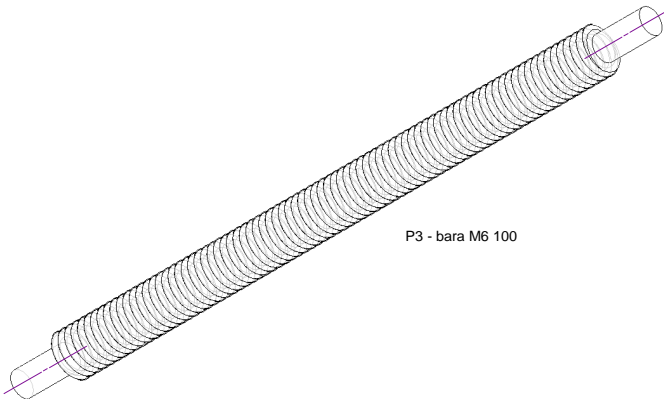
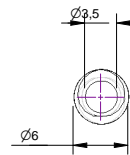
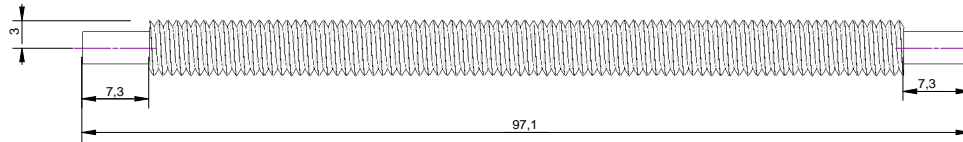
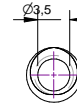
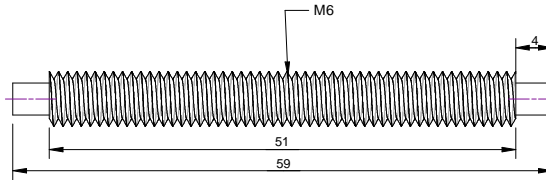

P3 - bara M6 100

Itemref	Quantity	Title/Name, designation, material, dimension etc			Article No./Reference	
Drawn by	Checked by	Approved by - date	File name	Date	Scale	
					Edition	Sheet

1

2

3

6

7

8

1

2

3

4

5

6

7

8

RevNo	Revision note	Date	Signature	Checked
-------	---------------	------	-----------	---------

A

B

C

D

E

F

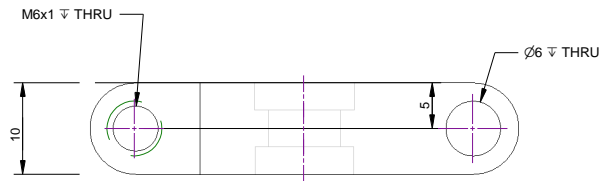
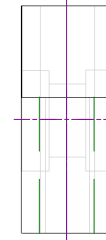
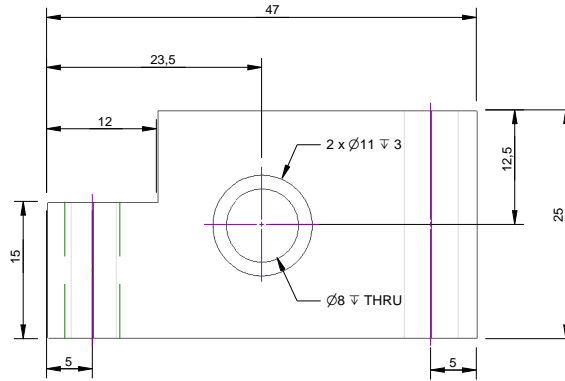
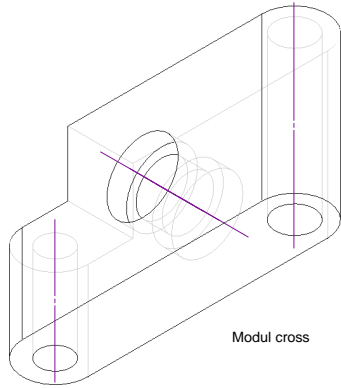

Itemref	Quantity	Title/Name, designation, material, dimension etc			Article No./Reference	
Drawn by		Checked by	Approved by - date	File name	Date	Scale
				Edition		Sheet

1

2

3

6

7

8

A

B

C

D

E

F

1

2

3

4

5

6

7

8

RevNo	Revision note	Date	Signature	Checked
-------	---------------	------	-----------	---------

A

B

C

D

E

F

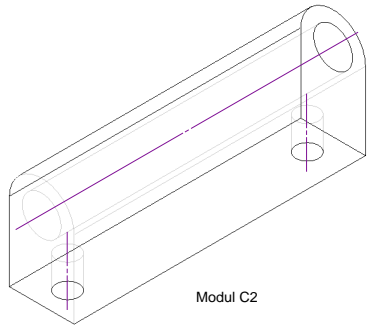

Modul C2

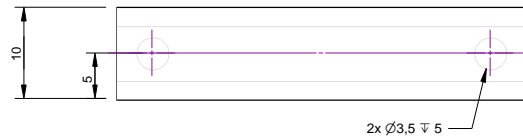
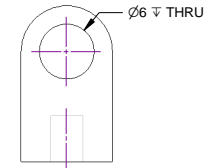
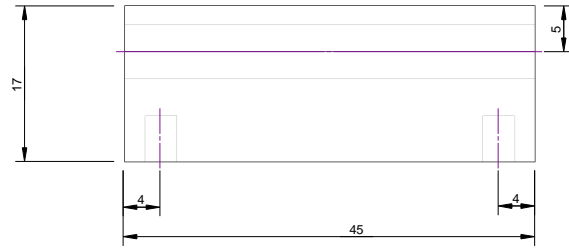

2x  $\varnothing 3,5 \nabla 45$

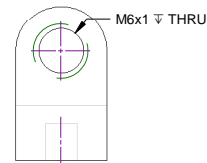
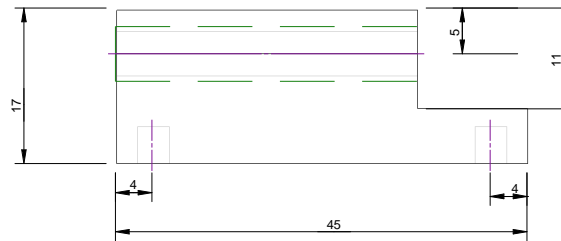

2x  $\varnothing 3,5 \nabla 45$

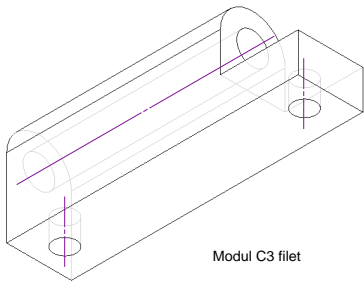

Modul C3 filet

Itemref	Quantity	Title/Name, designation, material, dimension etc			Article No./Reference	
Drawn by	Checked by	Approved by - date	File name	Date	Scale	
						Edition
						Sheet

1

2

3

6

7

8

A

B

C

D

E

F



1

2

3

4

5

6

7

8

RevNo	Revision note	Date	Signature	Checked
-------	---------------	------	-----------	---------

A

B

C

D

E

F

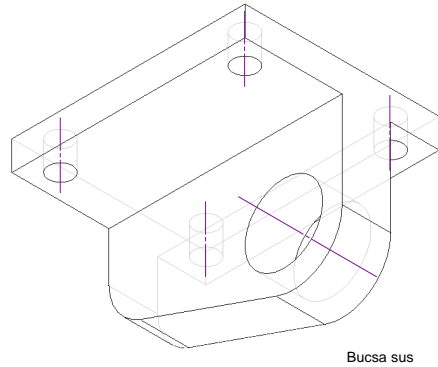

Bucsa sus

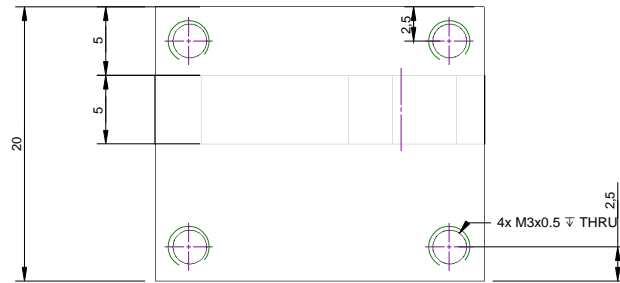
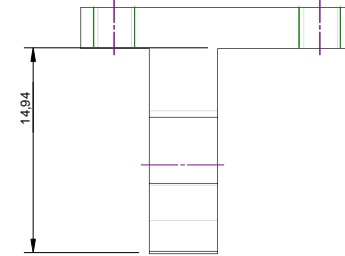
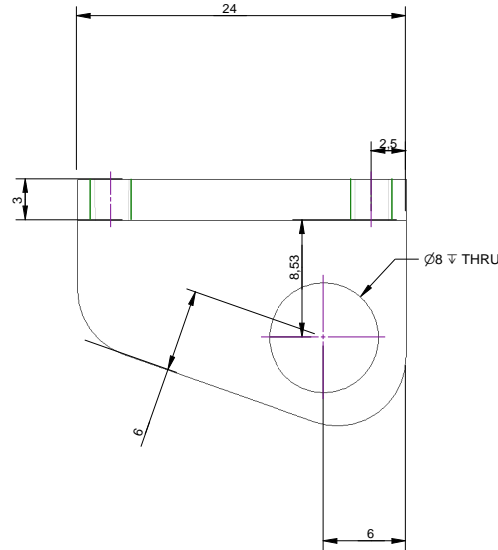

Itemref	Quantity	Title/Name, designation, material, dimension etc			Article No./Reference	
Drawn by	Checked by	Approved by - date	File name	Date	Scale	
					Edition	Sheet

1

2

3

6

7

8

A

B

C

D

E

F

1

2

3

4

5

6

7

8

RevNo	Revision note	Date	Signature	Checked
-------	---------------	------	-----------	---------

A

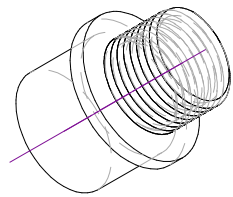

Bucsa jos

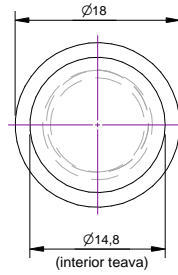
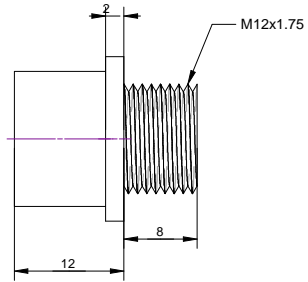

B

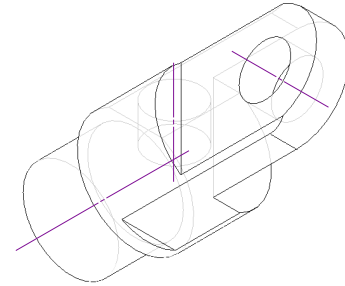

Bucsa intermediara 2

C

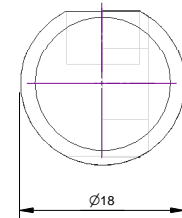
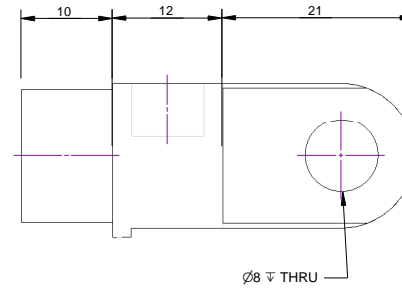
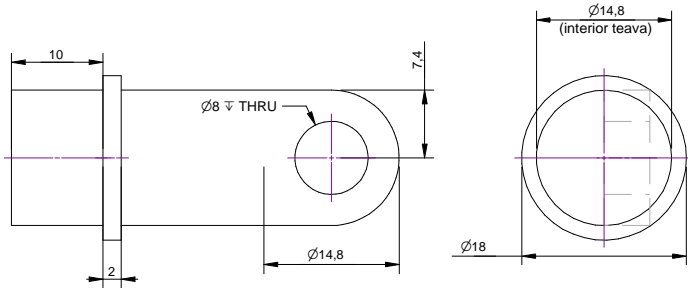

D

E

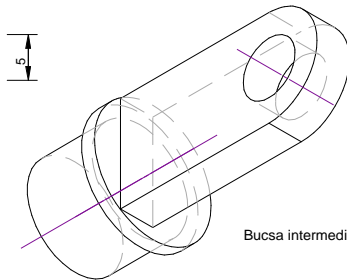
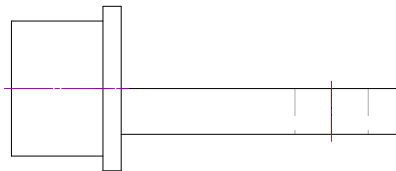

Bucsa intermediara

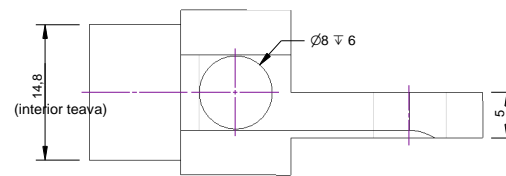

F

Itemref	Quantity	Title/Name, designation, material, dimension etc			Article No./Reference	
Drawn by		Checked by	Approved by - date	File name	Date	Scale
					Edition	Sheet

1

2

3

6

7

8

A

B

C

D

E

F

1

2

3

4

5

6

7

8

RevNo	Revision note	Date	Signature	Checked
-------	---------------	------	-----------	---------

A

B

C

D

E

F

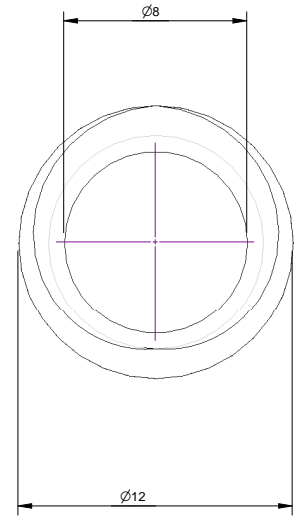
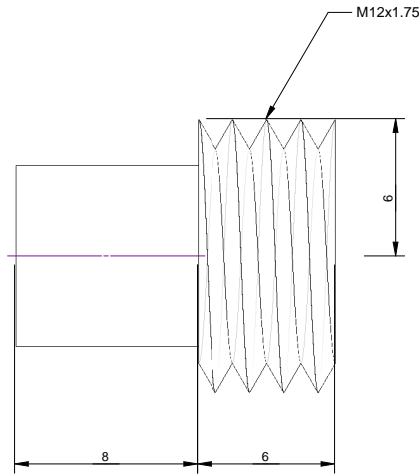
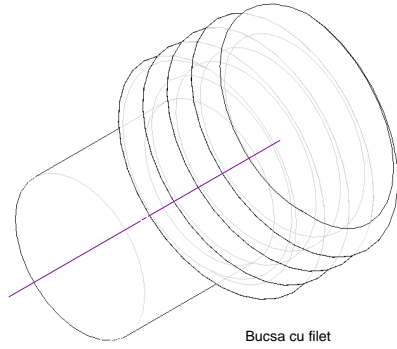

A

B

C

D

E

F

Itemref	Quantity	Title/Name, designation, material, dimension etc			Article No./Reference	
Drawn by	Checked by	Approved by - date	File name	Date	Scale	
					Edition	Sheet

1

2

3

6

7

8

1

2

3

4

5

6

7

8

RevNo	Revision note	Date	Signature	Checked
-------	---------------	------	-----------	---------

A

B

C

D

E

F

A

B

C

D

E

F

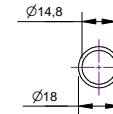
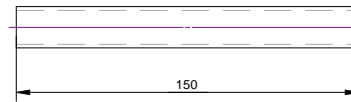
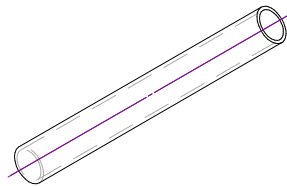
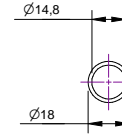
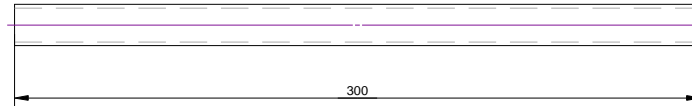
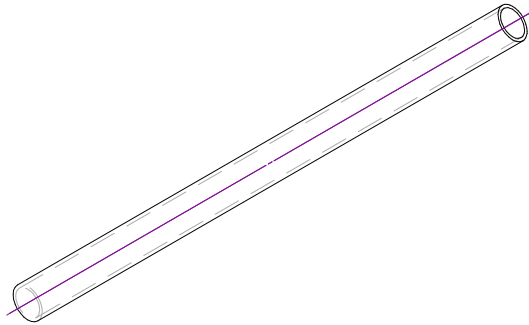

Itemref	Quantity	Title/Name, designation, material, dimension etc			Article No./Reference	
Drawn by		Checked by	Approved by - date	File name	Date	Scale
					Edition	Sheet

1

2

3

6

7

8

1

2

3

4

5

6

7

8

RevNo	Revision note	Date	Signature	Checked
-------	---------------	------	-----------	---------

A

B

C

D

E

F

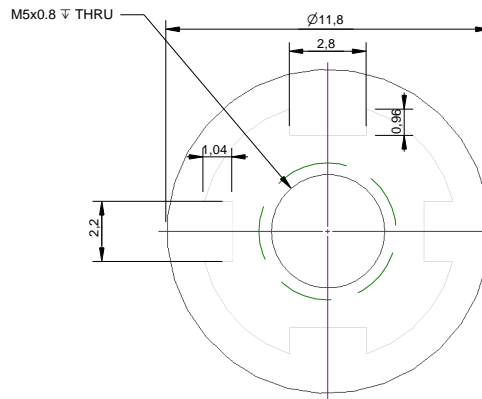
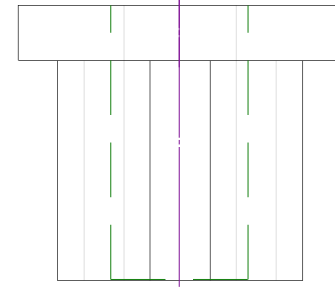
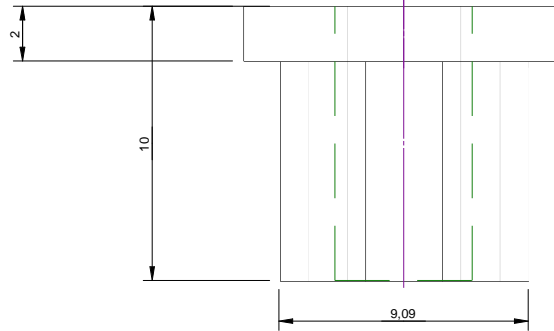
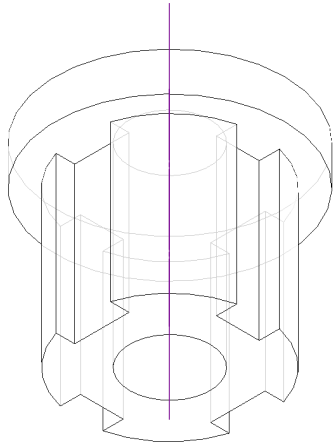

M5x0.8  $\nabla$  THRU

Itemref	Quantity	Title/Name, designation, material, dimension etc			Article No./Reference	
Drawn by		Checked by	Approved by - date	File name	Date	Scale
				Piesa prindere cardan		
					Edition	Sheet

1

2

3

6

7

8

A

B

C

D

E

F

1

2

3

4

5

6

7

8

RevNo	Revision note	Date	Signature	Checked
-------	---------------	------	-----------	---------

A

A

B

B

C

C

D

D

E

E

F

F

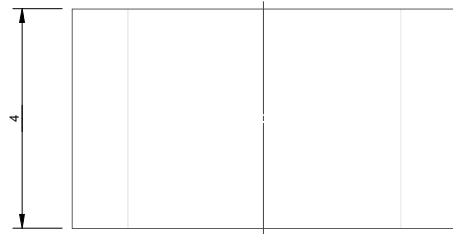
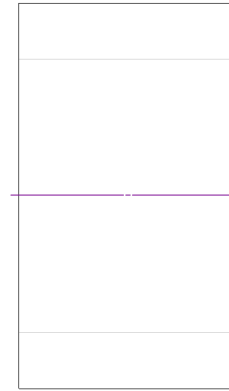
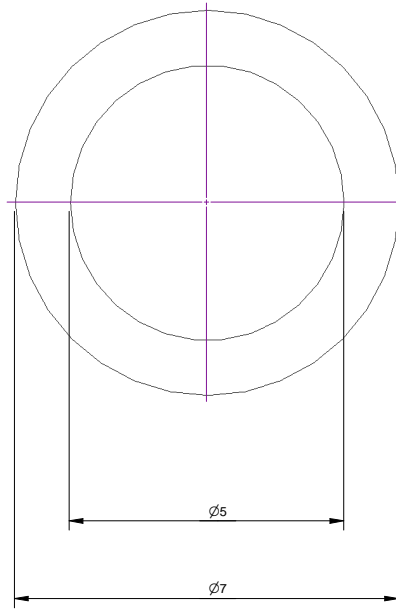
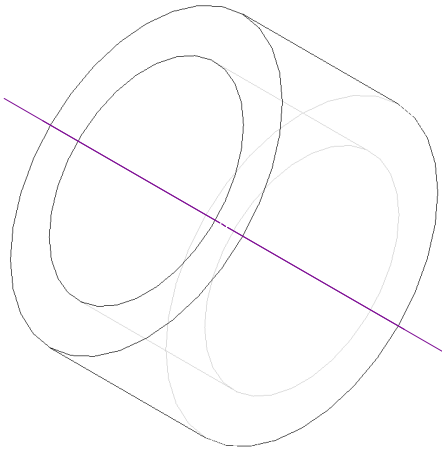

Itemref	Quantity	Title/Name, designation, material, dimension etc			Article No./Reference	
Drawn by		Checked by	Approved by - date	File name	Date	Scale
				Edition		Sheet

1

2

3

6

7

8

1

2

3

4

5

6

7

8

RevNo	Revision note	Date	Signature	Checked
-------	---------------	------	-----------	---------

A

B

C

D

E

F

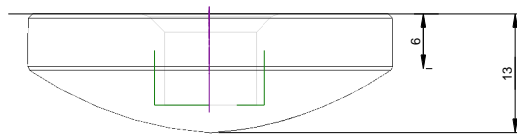
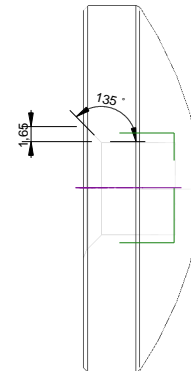
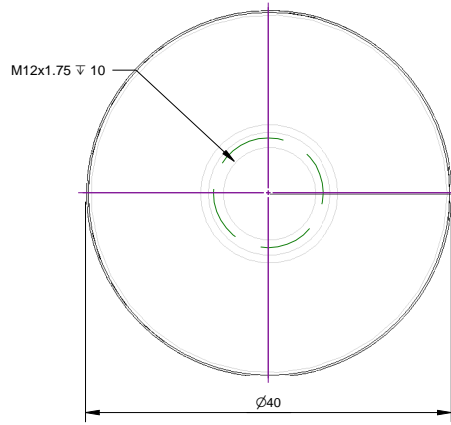
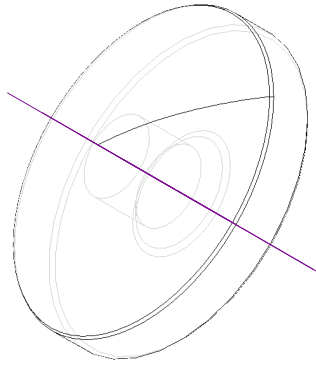

A

B

C

D

E

F

Itemref	Quantity	Title/Name, designation, material, dimension etc			Article No./Reference	
Drawn by		Checked by	Approved by - date	File name	Date	Scale
				Edition		Sheet

1

2

3

6

7

8

1

2

3

4

5

6

7

8

RevNo	Revision note	Date	Signature	Checked
-------	---------------	------	-----------	---------

A

B

C

D

E

F

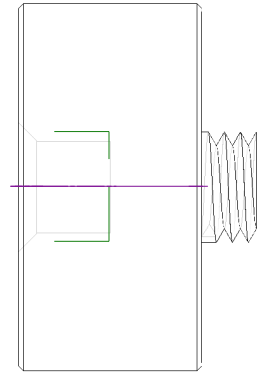
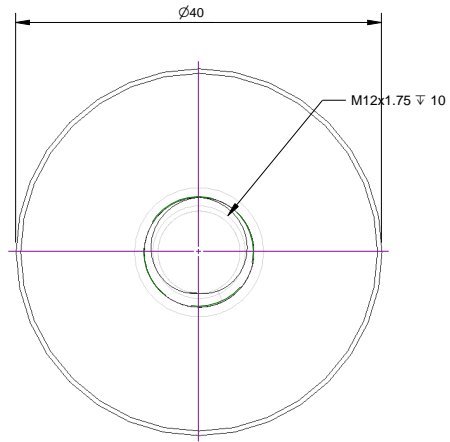
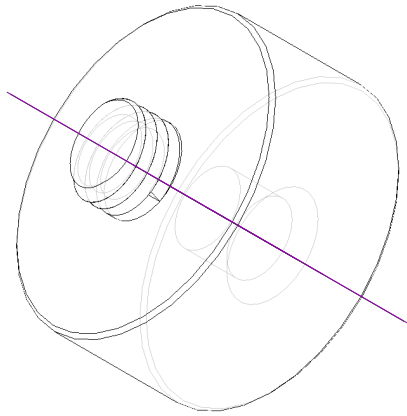

A

B

C

D

E

F

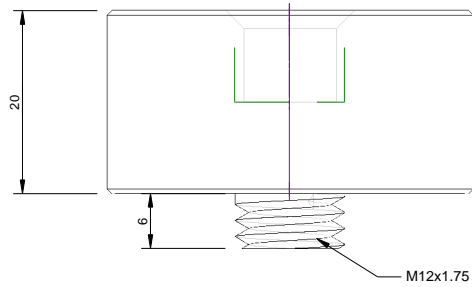

Itemref	Quantity	Title/Name, designation, material, dimension etc			Article No./Reference	
Drawn by	Checked by	Approved by - date	File name	Date	Scale	
					Edition	Sheet

1

2

3

6

7

8



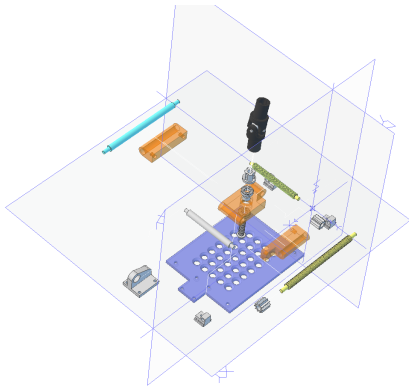

**Explode**

**Implode**

**Reset**

Step 3 :

Step 7 :

Step 5 :

Step 6 :

Step 4 :

Step 8 :

Step 10 :

Step 9 :

Step 12 :

Step 13 :

Step 21 :

Step 16 :

Step 17 :

Step 18 :

Step 19 :

Step 20 :

Step 1 :

Step 2 :

Step 22 :

Step 23 :